

NSO-SFA JOYSTICK

The NSO-SFA single axis mill duty controllers are characterized by their unmatched versatility and rugged construction. Space saving design, cast aluminum construction, IP56 housing, heavy-duty torsion spring and marine epoxy paint make this controller resistant to abuse and ideally suited for high-duty cycle mill applications and environmentally challenging marine applications.



SPECIFICATIONS

GENERAL DATA

# of Axis	Single
Output Options	Contacts, Potentiometer, Encoder, 4-20mA & Transformer
Joystick Action	Spring Return, Friction Brake or Maintained
Handle Travel	+/- 42 degrees each axis
Max # of Steps	Up to 7-0-7
Handle Compatibility	Standard Handles, Push Button, Mechanical Interlock, RH, BH, MG27
Life	10 million cycles
Materials	Powder-coated aluminum housing.
Est. Shipping Weight	3 lbs.

Est. Shipping Dimensions 13 in. x 10 in. x 6 in.

MOUNTING DATA

Mounting Style Drop-in

Mounting Footprint 2.56" x 2.56"
See literature for additional mounting specifications

ENVIRONMENTAL DATA

IP Rating IP56

Operating Temperature -4 to +140 degrees F [-20 to +60 degrees C]

Storage Temperature -40 to +140 degrees F [-40 to +60 degrees C]

ELECTRICAL DATA

Switch Type:
Double Pole Snap-In Contact Blocks

Max. Number:
Up to 10 contact blocks (20 circuits)

Max. Switching Capacity:
Making - 100 amps
Breaking - (0.7PF) 240V 80 amps

Contact Specifications Rating (AC):
Continuous 16 amps @ 240V
Resistive 8 amps @ 240V
Inductive 6 amps @ 240V

Termination:
Captive Saddle Clamp

Max. Wire Size:
12 AWG

Additional
Specifications

Reference product literature for additional specifications

Technical Drawings

Dimensional

All dimensions in inches [mm] and are subject to change.

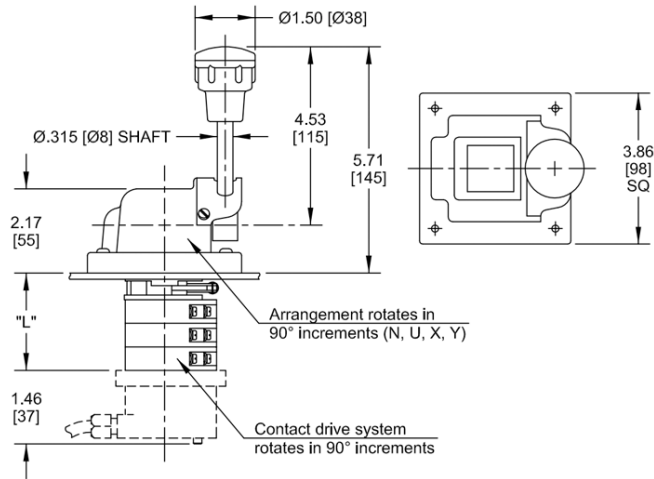

Contact Blocks:	1	2	3	4	5	6	7	8	9	10
Length "L":	1.57 [40]	2.17 [55]	2.76 [70]	3.35 [85]	3.93 [100]	4.52 [115]	5.12 [130]	5.71 [145]	6.30 [160]	6.89 [175]

Overall dimensions. Shown with standard 2 piece handle.

Mounting

All dimensions in inches [mm] and are subject to change.

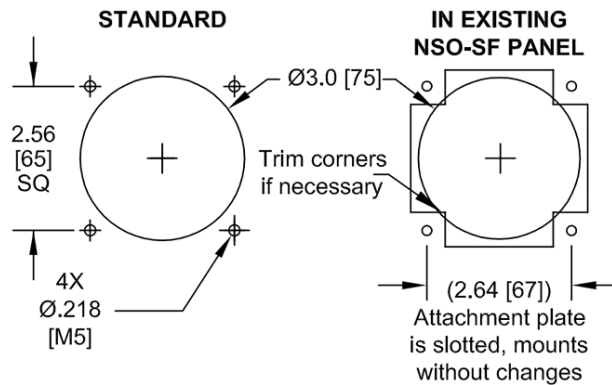

Mounting hole details

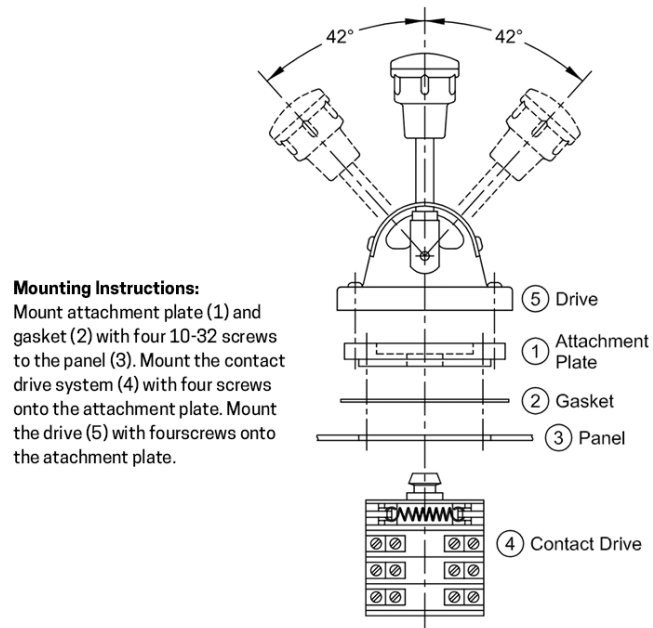

Mounting instructions for installation